

# Electrophoresis

## Goals for this unit:

1. Understand essential theoretical concepts of movement of a charged particle in an electric field.
2. Know types of media commonly used for electrophoresis and the difference between zonal and boundary methods
3. Be familiar with common applications:
  - PAGE / Ferguson plots
  - Nucleic Acid methods (sequencing gels / Southern blots)
  - SDS PAGE (theory and practice - DISC gels)
  - IEF gels (2D - gels)
4. Other Practical Aspects (tracking dyes / staining / applications)
5. Capillary Electrophoresis – DNA sequencing

*(Some of the electrophoresis notes given below are modified in part from notes by Terry Frey - San Diego State Univ.)*

# THEORY: Macromolecule accelerated by a force

$\mathbf{F} = q \mathbf{E}$  ( $q$  = net charge;  $\mathbf{E}$  is electric field strength).

Force causes an acceleration (recall Force = mass x acceleration;  $\mathbf{F} = m\mathbf{a}$ ).

**Limiting Velocity:** movement resisted by frictional force proportional to velocity.

$\mathbf{F}_f = f \mathbf{v}$  ( $f$  = frictional coefficient);

when  $\mathbf{F}_f = -\mathbf{F}$ , no more acceleration

==> molecule has reached its **limiting velocity**.

Define a mobility per unit field,  $U$

$$U = \frac{\mathbf{v}}{\mathbf{E}} = \frac{q}{f} \quad \text{compare } ==> \mathbf{s} = \frac{\mathbf{v}}{\omega^2 \mathbf{r}} = \frac{M(1-V\rho)}{f} \quad \text{for sedimentation}$$

**Stokes Law:** For a spherical molecule of radius,  $r$ , and charge  $z e$  ( $e$  = elementary charge, charge on 1 electron)

$$U = \frac{z e}{6\pi\eta r_h} \quad \leftarrow \text{from Stokes law, } f = 6\pi\eta r_h$$

where  $r_h$  is radius of sphere of equal vol,  $\eta$  is viscosity ( $\sim 0.01\text{g/cm-sec}$ ).

# Rigorous quantitative treatment is difficult

Electric field felt by macromolecule is difficult to evaluate. The macromolecule is a very large ion in solution with many **counterions**.

**Very Low Ionic Strength** -- Once the macromolecule is separated slightly from its **counter-ions**, it takes enormous energy to pull them further apart ==> charge separation **counteracts the external field** resulting in little or no molecular transport.

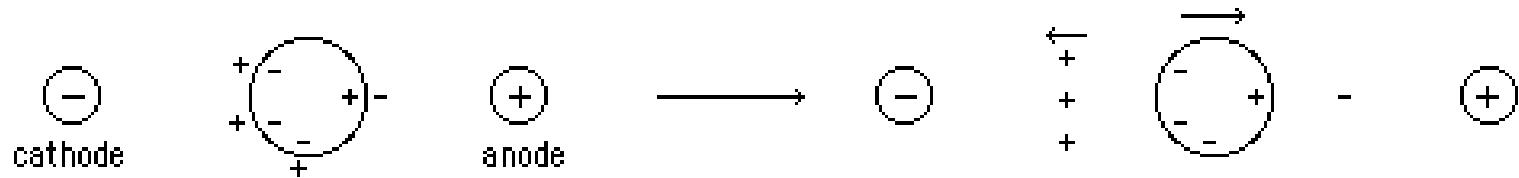

**Very High Ionic Strength** -- overcomes the problem of charge separation (the macromolecule will always have enough counter-ions around). But this creates an ion cloud around the particle **partially shielding** it from the external field. This does not prevent electrophoretic movement, but it does complicate rigorous analytical treatment.

Most electrophoretic experiments (whether preparative or analytical) are **analyzed semi-empirically**.

# Experimental: Media -- Three common types

1. **Starch Gel** -- swollen potato starch granules (used for prep isoelectric focusing)
2. **Agarose Gel** -- purified large MW polysaccharide (from agar) ==> very open (large pore) gel used frequently for **large DNA** molecules
3. **Polyacrylamide Gels** -- most commonly used gel because they are very stable and can be made at a wide variety of concentrations or even with a gradient of concentrations ==> large variety of pore sizes

7.5% (45K-400K) / 10% (22K-300K) /

12% (13K-200K) / 15% (2.5K-100K)

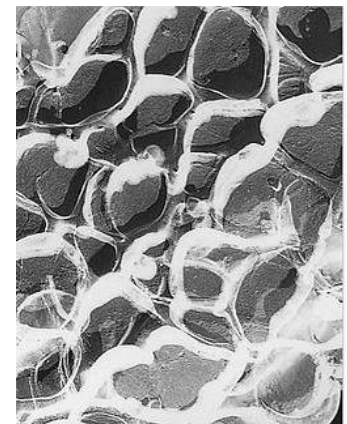

Transmission-Electron Microscopic image of a polyacrylamide gel. The pore size of a gel is determined by the total amount of monomer present (%T) and the amount of cross-linker (%C).

**Acrylamide Concentrations** -- typically 5-20% by weight (5%, 7.5%, 10%, 12.5%, 15%, 20% common) ==> gel is mostly water.

Acrylamide polymerizes in head-to-tail fashion to form long polymers which form a complex network held together by bis-acrylamide crosslinks. The crosslinking polymers create pores in the gel with the size of pores determined by the acrylamide concentration.

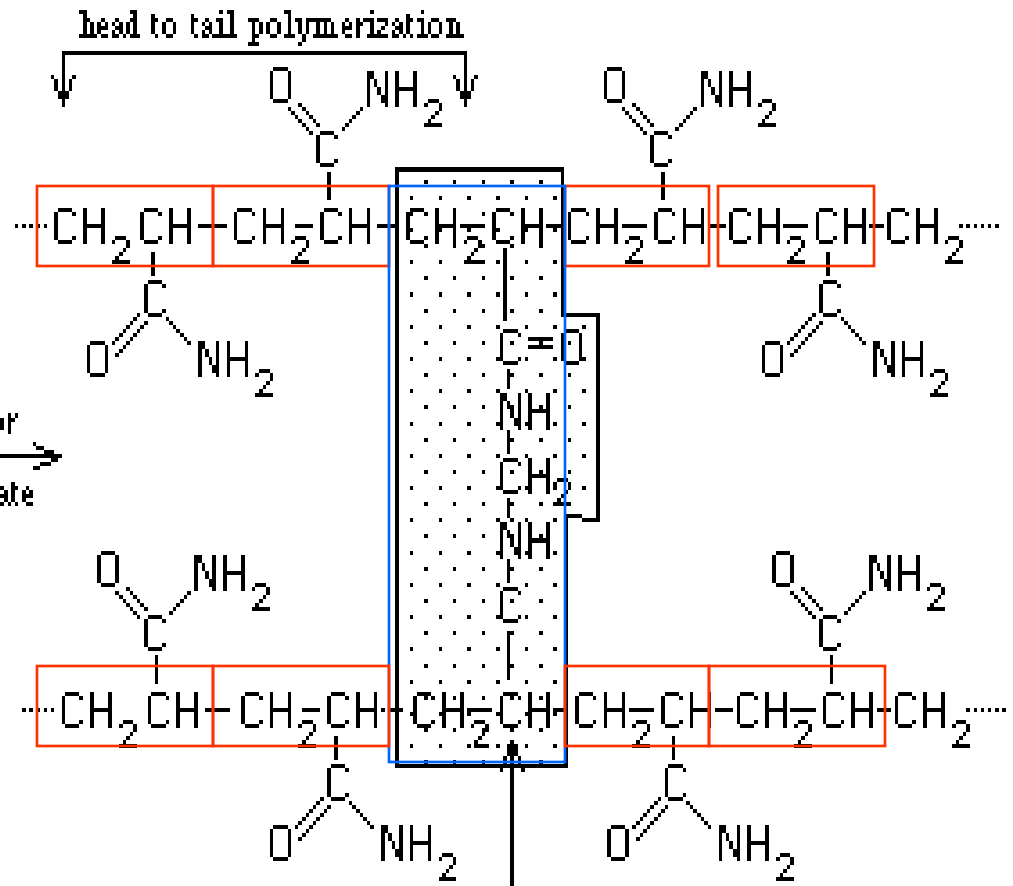
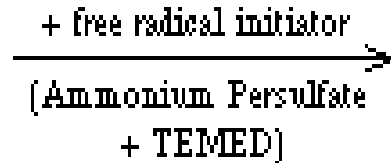
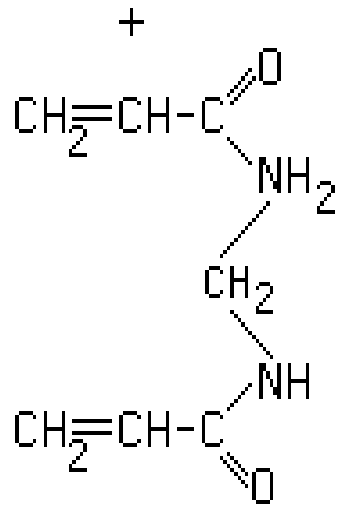
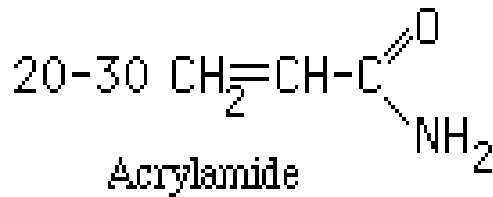

N,N'-methylene-bis-acrylamide

bis-acrylamide crosslinks linear polymers of acrylamide

# Terms: Boundary and Zonal

**Boundary:** measure the rate of movement of the boundary and calculate  $U$  from  $E$  and  $v$  -- rarely used

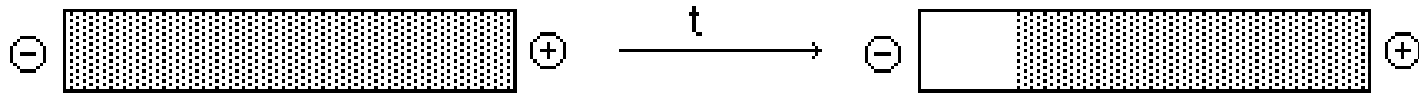

**Zonal:** (~zonal sedimentation; ~ sucrose density gradients)

need some way of stabilizing the zones to prevent mechanical mixing (from vibrations) or convection mixing (from temperature differences)

For example - Paper Electrophoresis

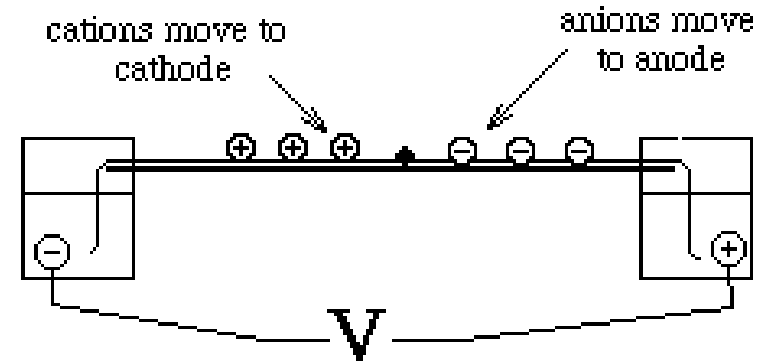
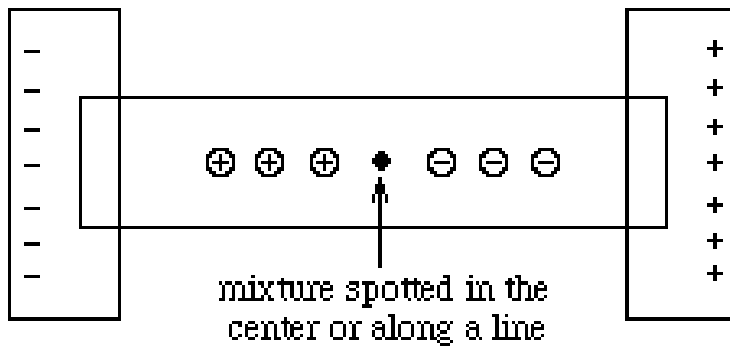

==> must use a high voltage, otherwise they diffuse too rapidly ==> paper must be cooled (usually by water)

# Common Applications: PAGE / Ferguson Plots

Log relative mobility vs. % Gel conc.:

$$\log U = \log U^{\circ} - K[C]$$

Ferguson Plot

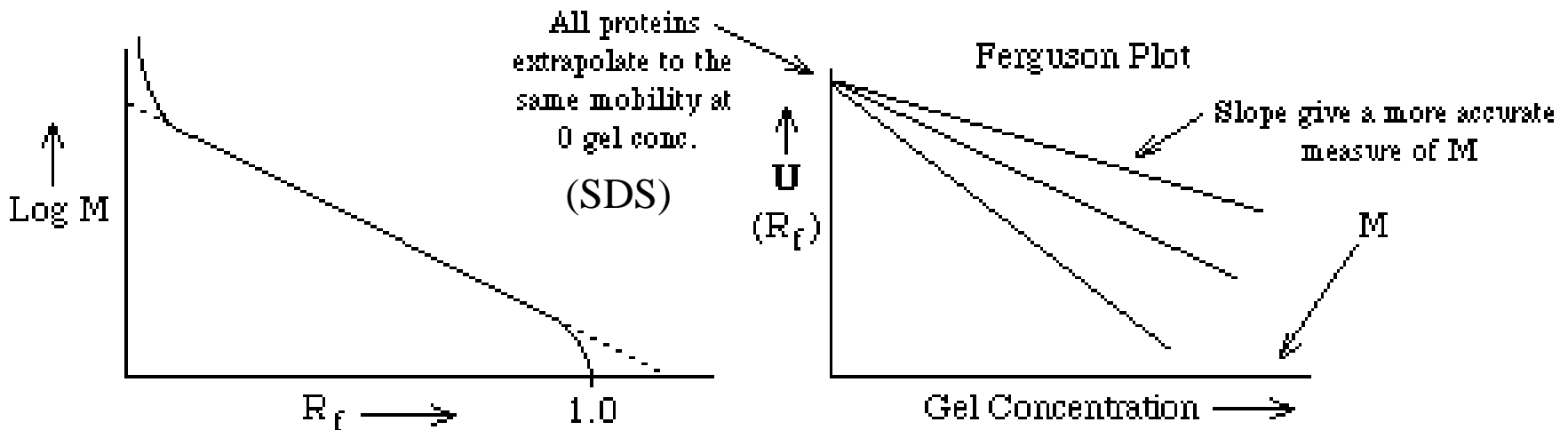
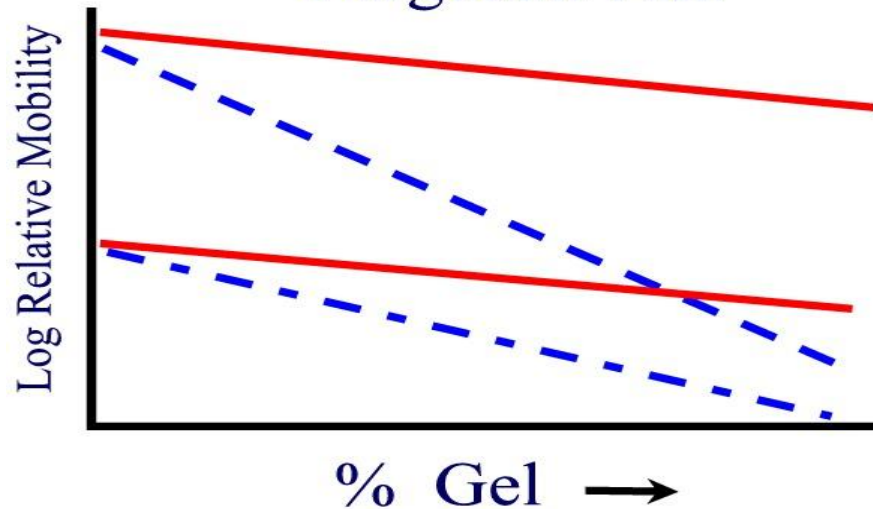

# Common Applications: Nucleic Acid Apps

Log relative mobility vs. % Gel conc.:

$$\log U = \log U^{\circ} - K[C]$$

$$U = \frac{ze}{f} = \frac{ze}{6\pi\eta r_h}$$

Z is **proportional** to the number of nucleotides and thus M (molecular weight)

f is **proportional to M** (for molecules with similar shapes)

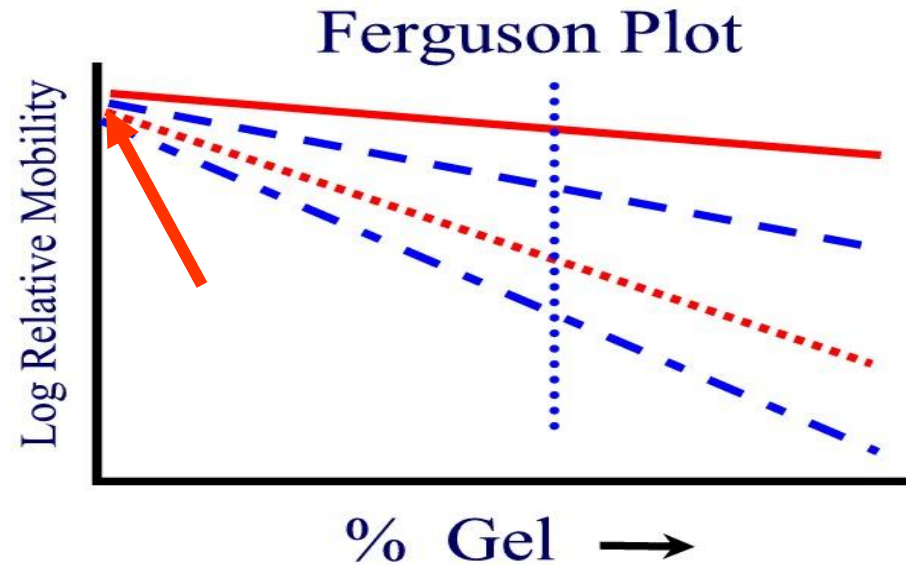

**Thus, U should be ~ independent of the size of the nucleic acid.**

(Cal Tech – verified for 1 to  $1.7 \times 10^{(+5)}$  nucleotides)

**==> Do electrophoresis in a gel matrix -- gel sieves the molecules**

**Agarose: 0.2 % for Nucleic Acids up to  $M = 150 \times 10^6$**

**0.8 % for Nucleic Acids up to  $M = 50 \times 10^6$**

**Polyacrylamide: for smaller Nucleic Acids; choose % acrylamide to produce correct size pore**



# Dideoxy sequencing

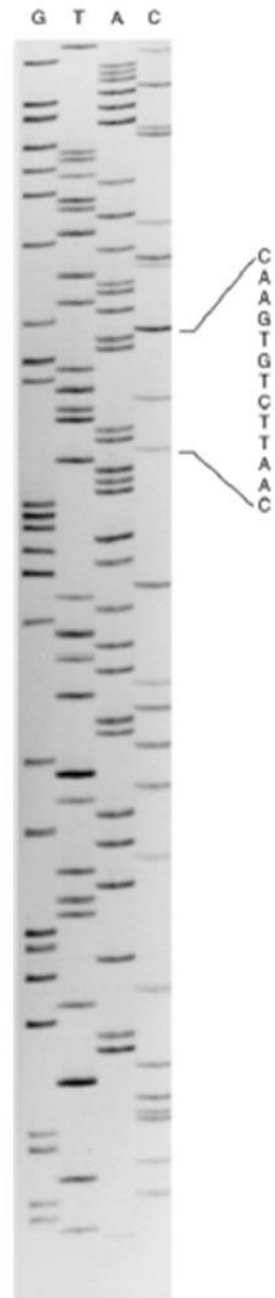
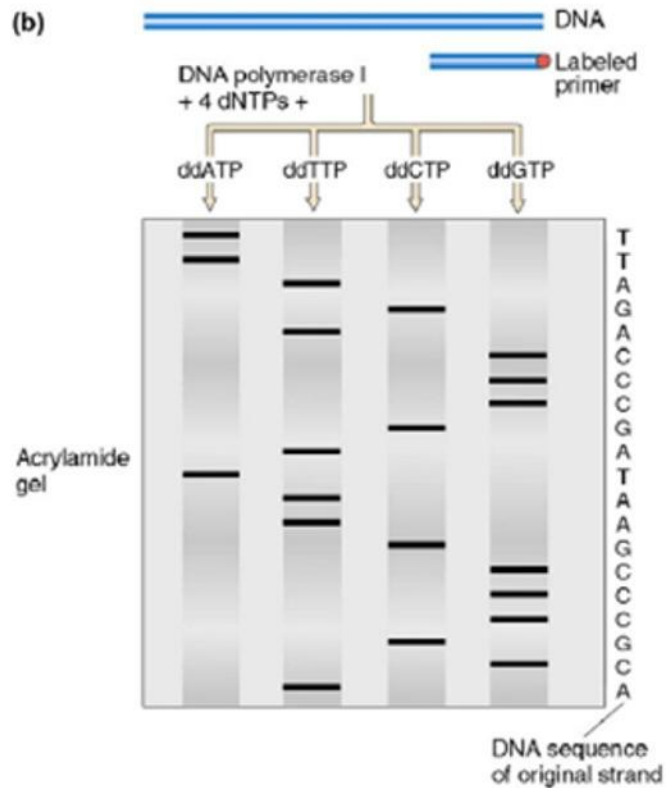
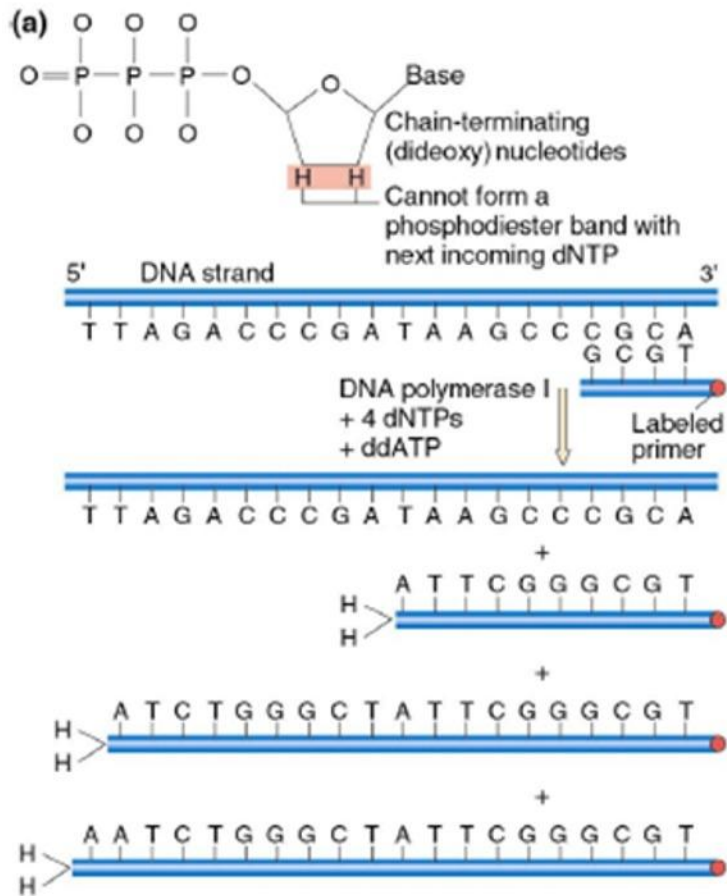

# Common Applications: SDS PAGE

Electrophoresis of "native" proteins is relatively rare except for **Isoelectric Focusing** described later.

What is needed is a way of **modifying proteins so  $\zeta$  is proportional to  $M$**  (as is the case with nucleic acids).

## Sodium Dodecyl Sulfate =

$\text{CH}_3(\text{CH}_2)_{11}\text{SO}_3^- \text{Na}^+$  A detergent / **amphipathic**, denatures proteins by binding to the polypeptide backbone. Most proteins bind

**~1.4 gm SDS/gm protein**

1 SDS / 1.5-2 peptide bonds

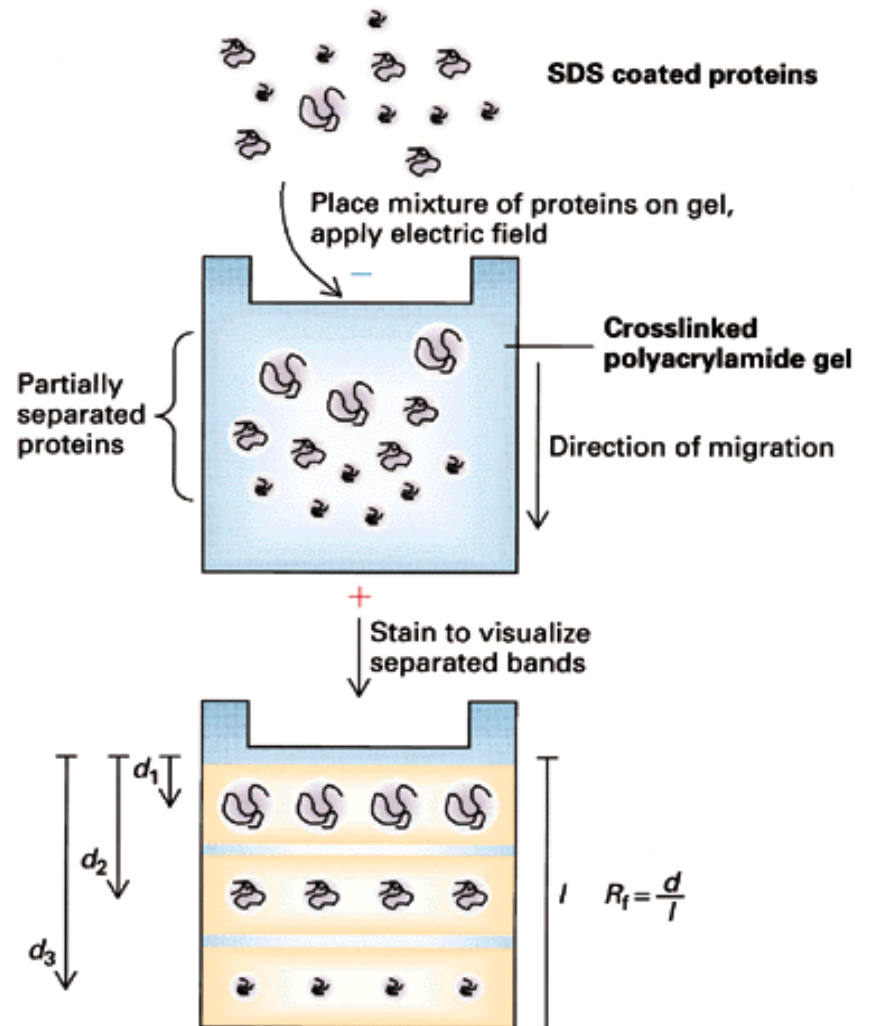
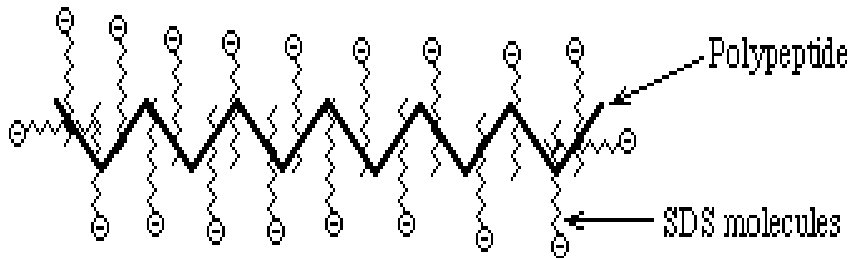

# Common Applications: DISC PAGE + SDS

## Discontinuous Electrophoresis

**2 layers:** **upper layer** contains **low mobility ions**;  
**lower layer** contains **high mobility ions**

The two zones move down with a **sharp boundary** between them. Why? Should not the faster, lower buffer ions should move further ahead, leaving slow ones behind? But - they experience different potentials:  $V_U \gg V_L$

**Ohms Law:  $V = R I$  and  $I =$  current and is the same for both layers**

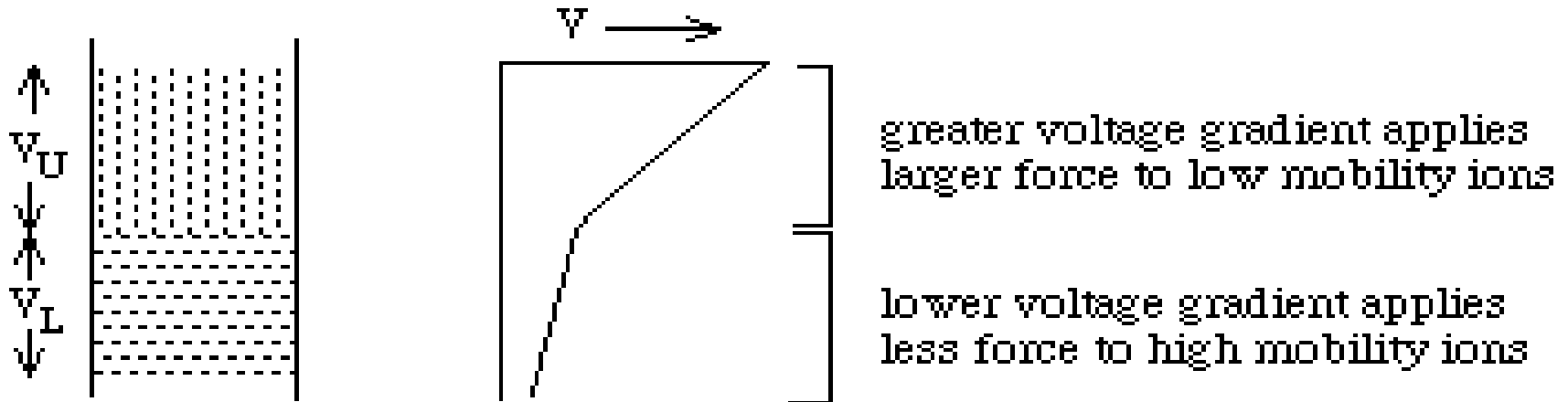

*Why a sharp boundary? If a mobile lower zone ion drifts into the upper zone, it experiences a higher potential,  $V_U$ , and speeds up until it reaches the lower zone where the lower potential,  $V_L$ , causes it to slow down again. If a low mobility upper zone ion drifts into the lower zone, it experiences a lower potential,  $V_L$ , and slows down until it drifts back into the upper zone.*

# DISC PAGE + SDS

Choose upper and lower zone ions so that:  $m_U < m_{\text{proteins}} / \text{SDS} < m_L$   
 Cl<sup>-</sup> vs. proteins / SDS vs. Gly

[mobility of Gly varies with pH; (pH 6.7, Gly ~0 / > pH 8.9, Gly ~ -1)]

Upper "**stacking gel**" - proteins / SDS > Gly ~ (0)

Lower "**running gel**" - Gly ~ (-) > proteins / SDS

==> proteins will be concentrated at the interface into **thin zones stacked in order of protein mobility**. Note: all this assumes electrophoresis in a "**stacking gel**" with large pores which do not inhibit protein movement.

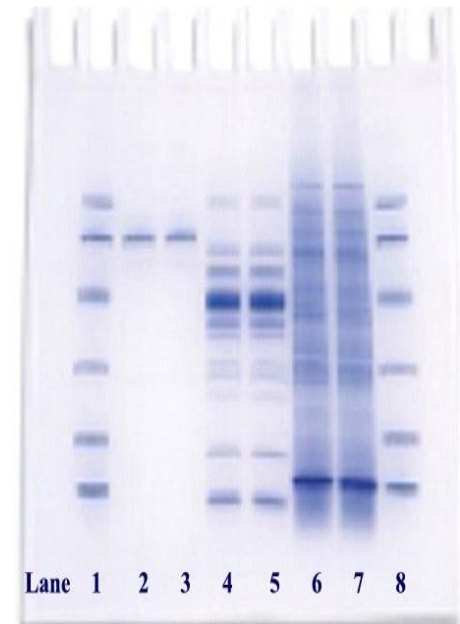
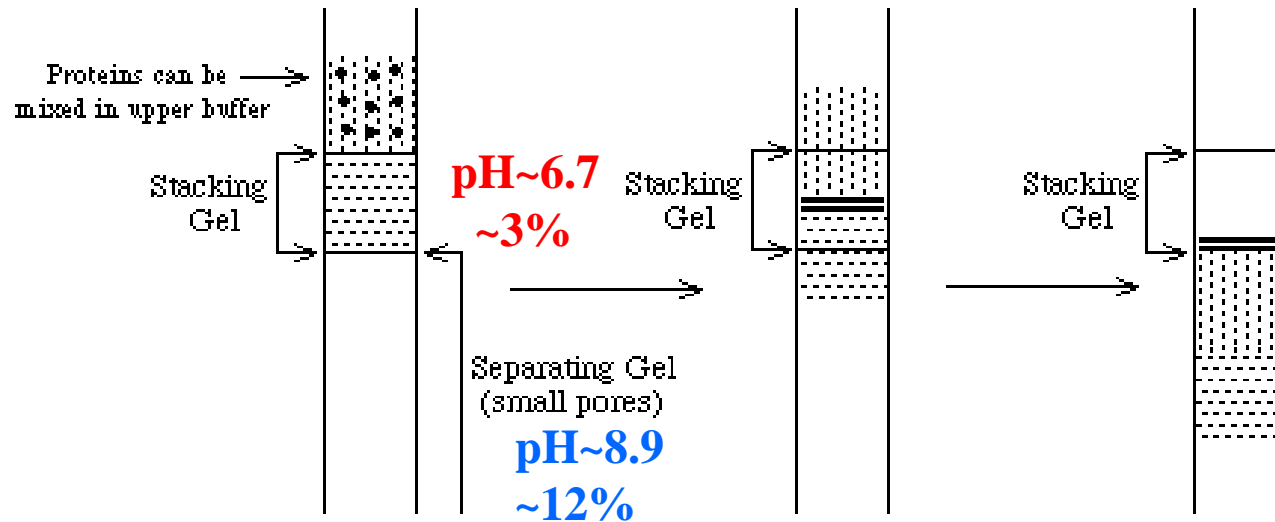

# Applications: Isoelectric Focusing

All proteins carry charges that vary from a net positive charge at low pH (-COOH and  $\text{-NH}_3^+$  forms of acidic and basic functional groups), through 0 at some intermediate pH, to a net negative charge ( $\text{-COO}^-$  and  $\text{-NH}_2$  forms) at high pH.

**pI - Isoelectric Point:** pH at which a protein has a net 0 charge (positive and negative charges balance). Depends mostly on the amino acid composition and a little on the tertiary structure

**Create a pH gradient in a gel:** Can be done on a slab (vertical or horizontal) or a tube (Equilibrium Density Gradient Centrifugation (IsoPycnic Centrifugation))

# Applications: Isoelectric Focusing

## How to make a stable pH gradient?

Must have a buffer for each pH along the gradient ==> **Ampholytes**

small organic molecules with different combinations of acidic and basic groups so that each one has a different pKa. If one electrophoreses a mixture of ampholytes (polyampholytes) with  $\text{H}_3\text{PO}_4$  in the Anode buffer reservoir (to buffer at very low pH) and  $\text{NaOH}$  in the Cathode buffer reservoir (to buffer at very high pH), each ampholyte will migrate to a pH equal to its pKa and buffer the pH at that point.

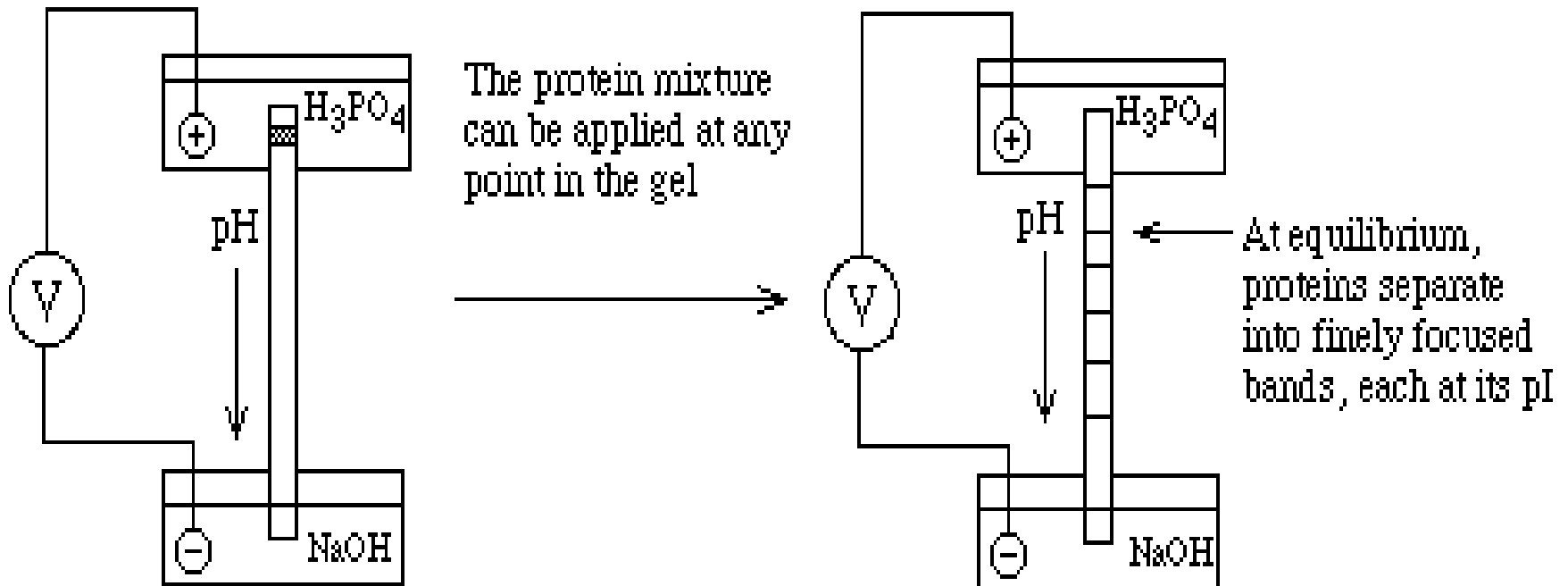

# Applications: 2D Electrophoresis

Most common:

**Isoelectric  
Focusing in tube  
gels and SDS-  
PAGE in slab  
gels**

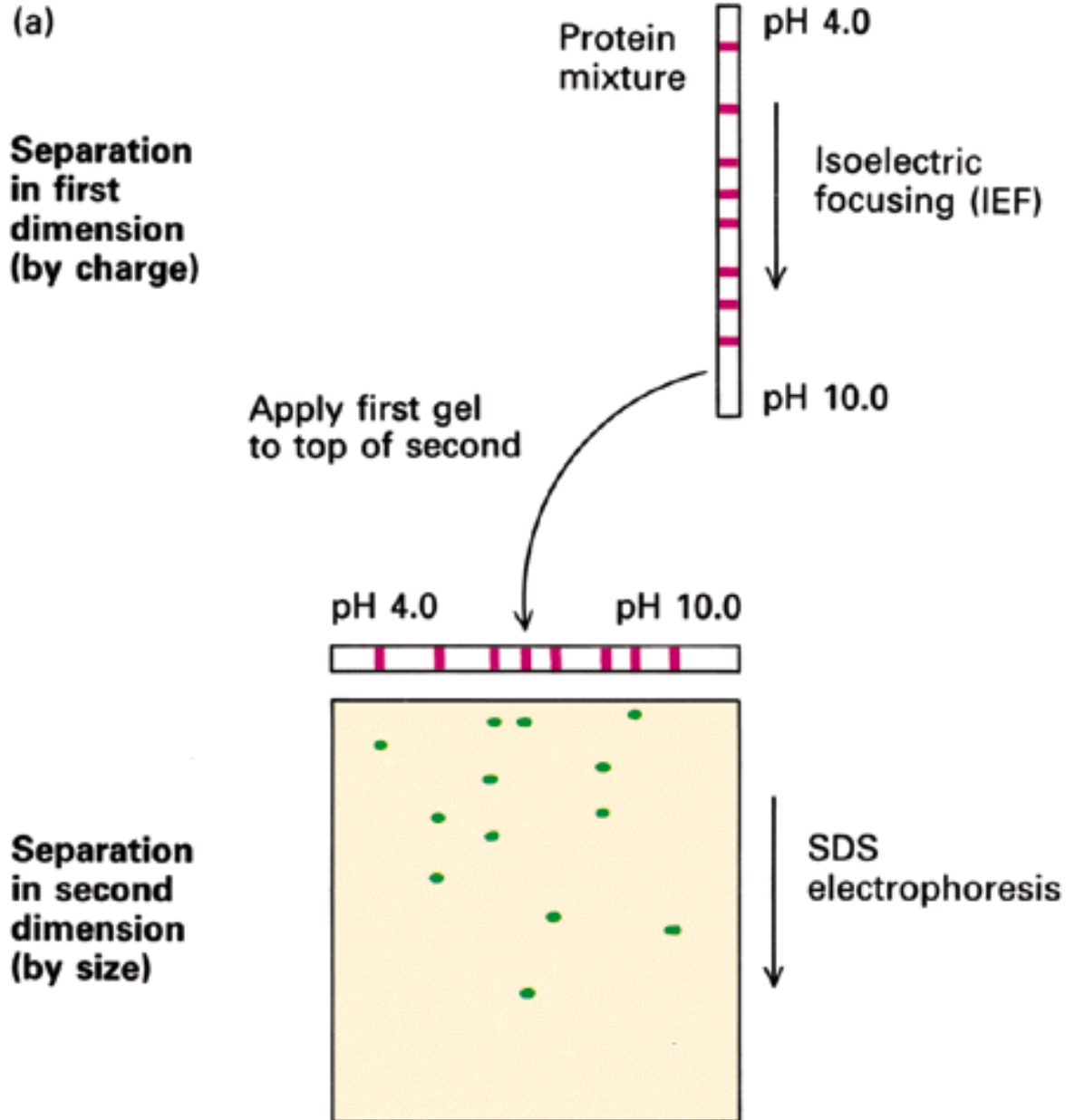

# Clinical Applications: 2D Electrophoresis

Use 2D gels to **monitor how each protein changes during:**

- a) **Development;**
- b) **Transformation;**
- c) **Disease states;**
- d) **Activation -- e.g. by a hormone etc.**

2D gel has a complex mixture of proteins separated by **pI along the horizontal axis** and by **log M along the vertical axis**. Can resolve thousands of spots (proteins) by this technique. Analysis is now automated by computer so that one can do 2D gels on whole cell extracts.

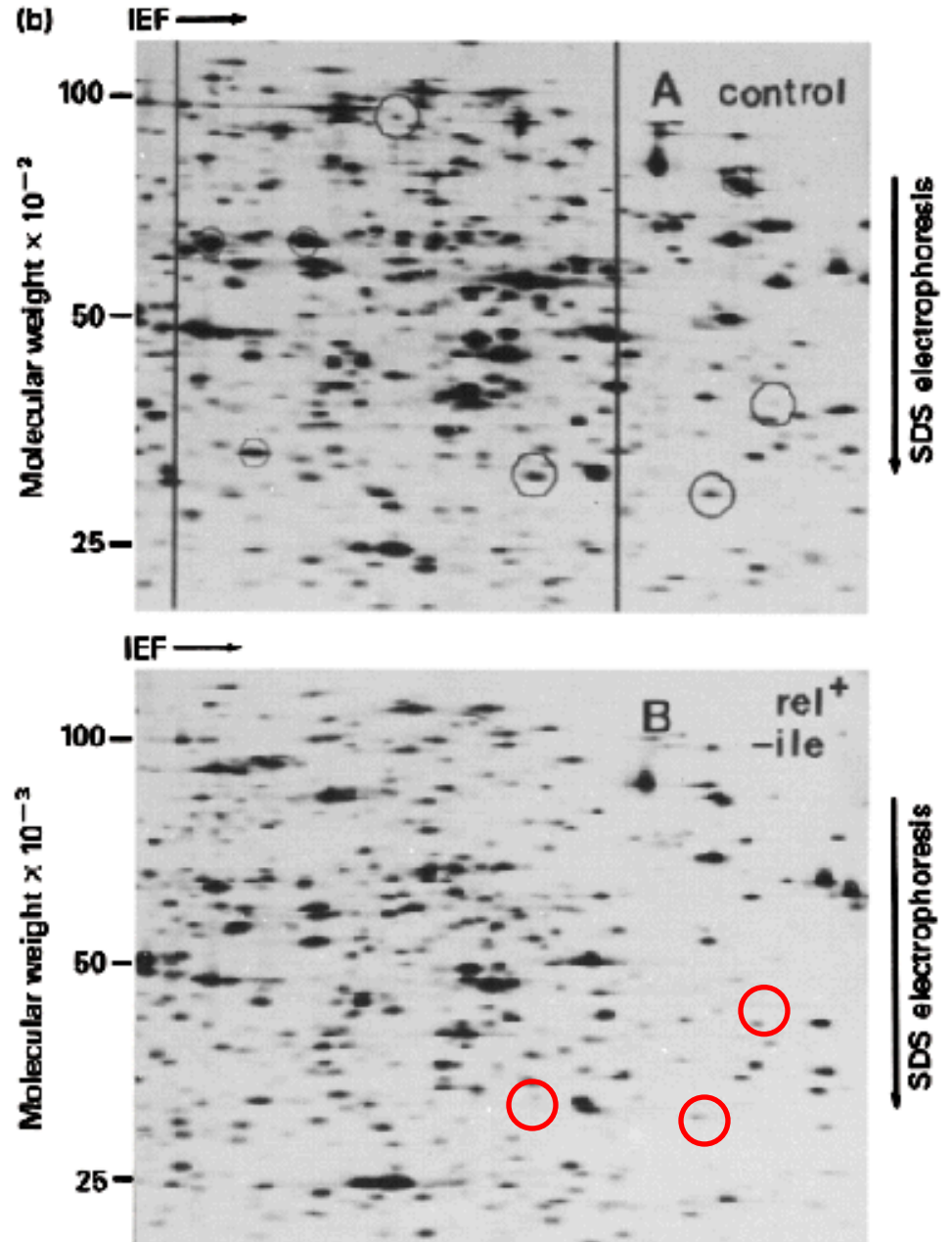



# Other Practical Aspects (dyes and stains)

**Tracking Dye:** bromophenol blue (+) / methylgreen (-)

**Staining:** **Coomassie Blue** / **Silver** / **SYPRO orange**

---

**Coomassie Blue**

50 ng / band

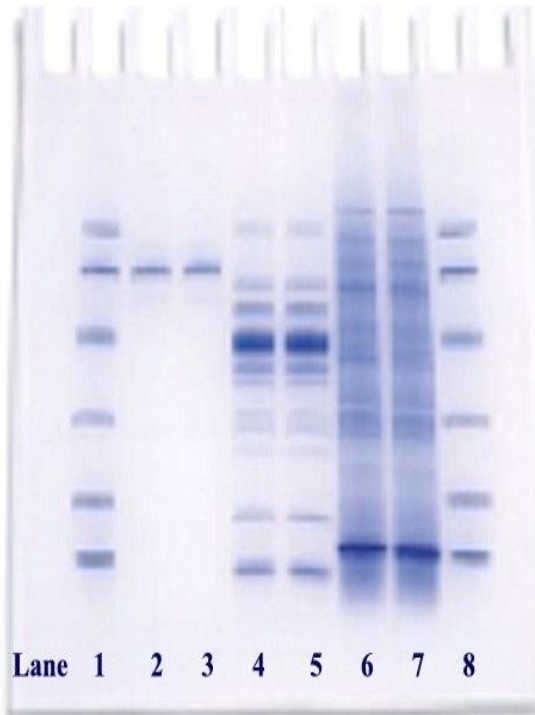

**Silver**

2-5 ng / band

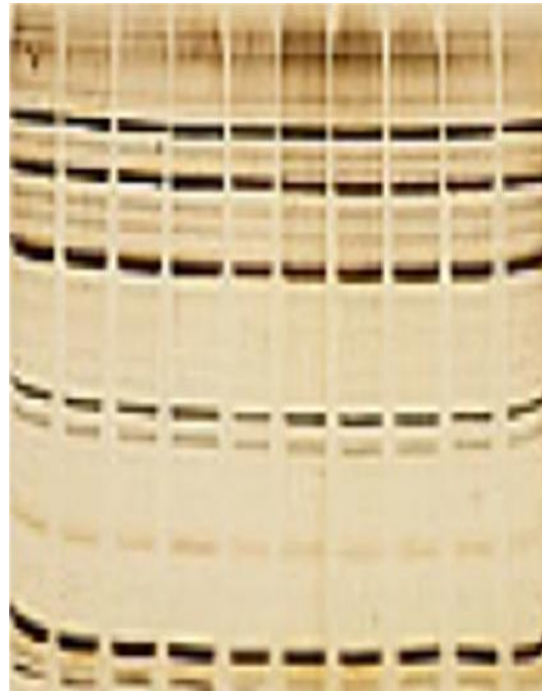

**SYPRO orange**

2-3 ng / band

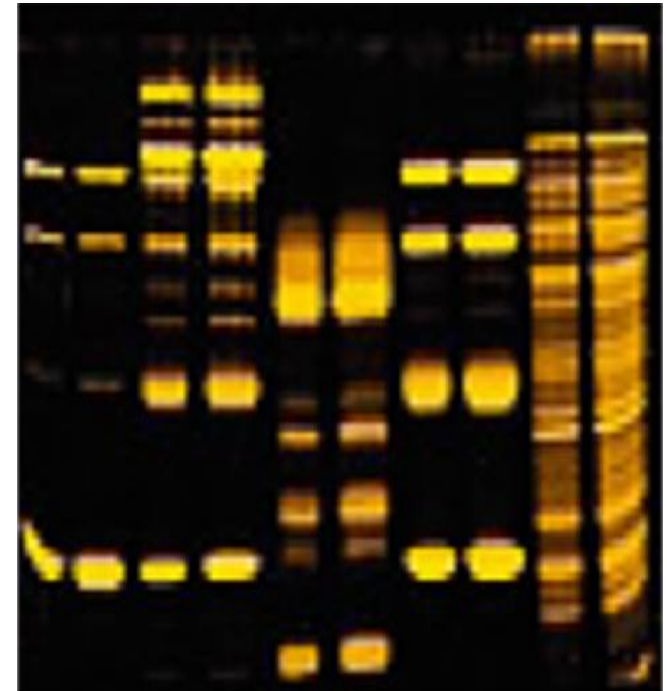

# SYPRO<sup>®</sup> Orange

SYPRO Orange stain (Molecular Probes, Inc.) is a novel fluorescent dye for the detection of proteins separated by SDS or native polyacrylamide gel electrophoresis. The staining procedure is simple, rapid and sensitive. (An excellent report describing in detail the use of SYPRO Orange to stain protein gels can be found in Malone et al., *Electrophoresis*, 2001, 22, 919-932.)

The detection limit for SYPRO Orange-stained proteins using a DR transilluminator is around 2 - 3 ng both by eye and using Polaroid 667 film. This level of sensitivity, especially by eye, is significantly greater than that obtained using a UV device (about 20 ng).

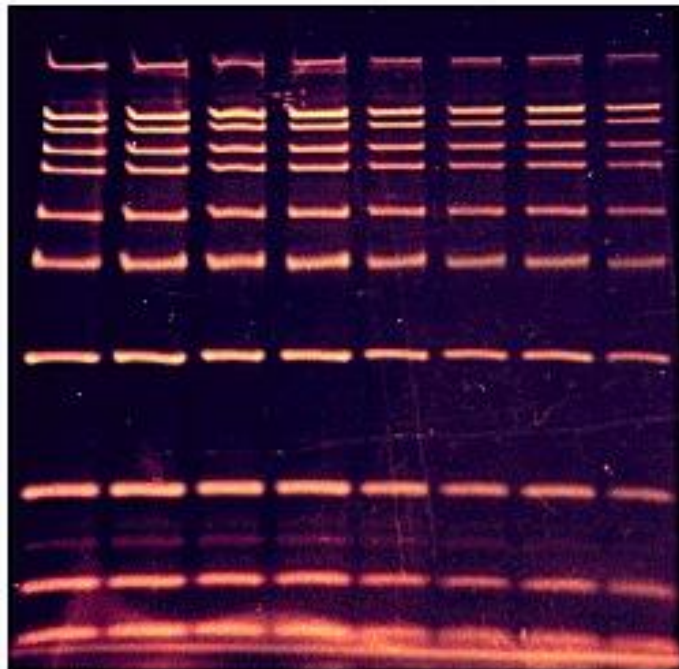

Molecular weight standards were subjected to SDS PAGE. After electrophoresis, the gel was stained with SYPRO Orange and photographed on a Dark Reader transilluminator using Polaroid 64 color film.

The protein load on this particular gel ranged from 120 ng to 15 ng of protein per band (left to right). The inset shows the same gel stained with Coomassie Blue.

Not only is the sensitivity of SYPRO Orange much greater than that of Coomassie Blue, but the entire procedure is complete in 20 minutes. After Coomassie staining, on the other hand, the gel has to be de-stained for several hours.

# Southern Blot (Edwin Southern – mid 1970's)

Gel electrophoresis

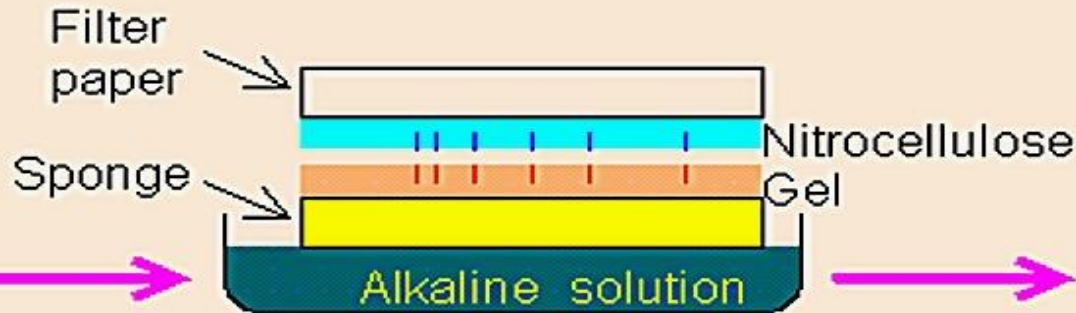
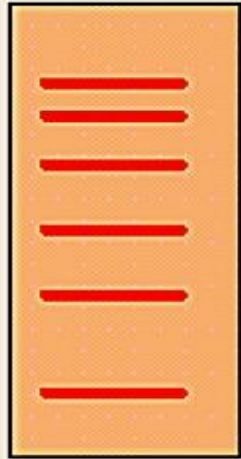

Nitrocellulose filter

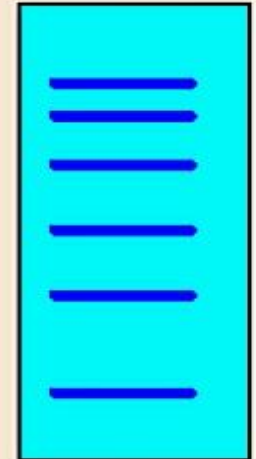

Hybridize  
with probe

Autoradiogram



**Southern blotting** is a technique for detecting specific **DNA** fragments in a complex mixture. DNA fragments are denatured with alkaline solution.

**Northern blotting** is a technique for detecting specific **RNA** fragments in a complex mixture. RNA fragments are treated with formaldehyde to ensure linear conformation.



# RFLPs - Restriction Fragment Length Polymorphisms

**Polymorphism** refers to the DNA sequence variation between individuals of a species. If the sequence variation occurs at the **restriction sites**, it could result in RFLP. The most well known example is the RFLP due to  $\beta$  globin gene mutation.

Normal cell

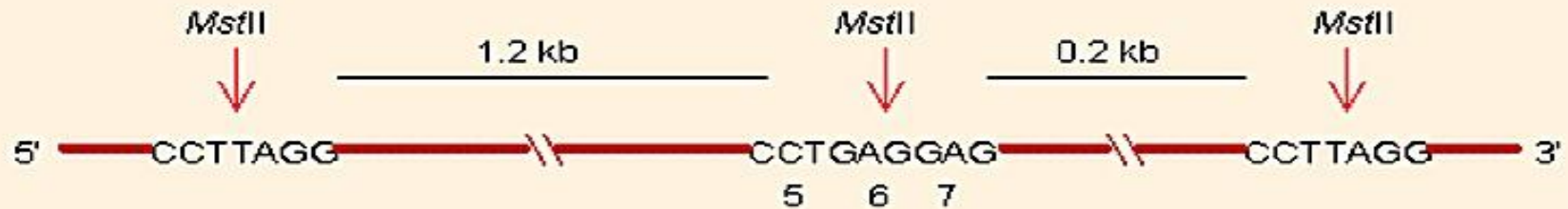

Sickle cell

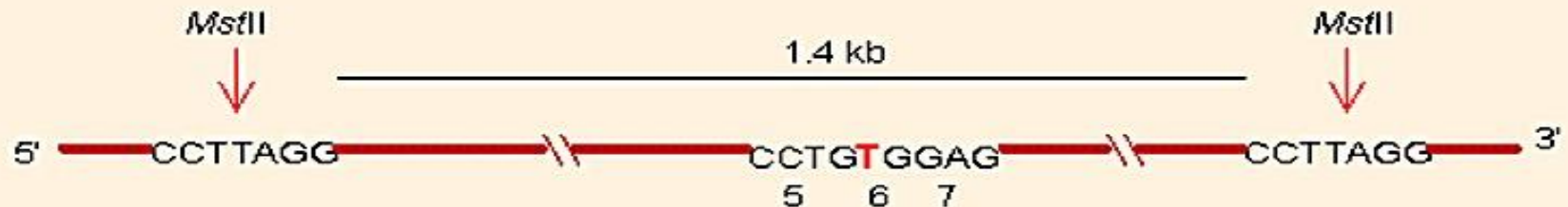

**RFLPs** resulting from  $\beta$ -globin gene mutation. In the normal cell, the sequence corresponding to 5th to 7th amino acids of the  $\beta$ -globin peptide is CCTGAGGAG, which can be recognized by the restriction enzyme *MstII*. In the sickle cell, one base is mutated from A to T, making the site unrecognizable by *MstII*. Thus, *MstII* will generate 0.2 kb and 1.2 kb fragments in the normal cell, but generate 1.4 kb fragment in the sickle cell. These different fragments can be detected by **Southern blotting**.

# Western Blot (a.k.a. protein immunoblot)

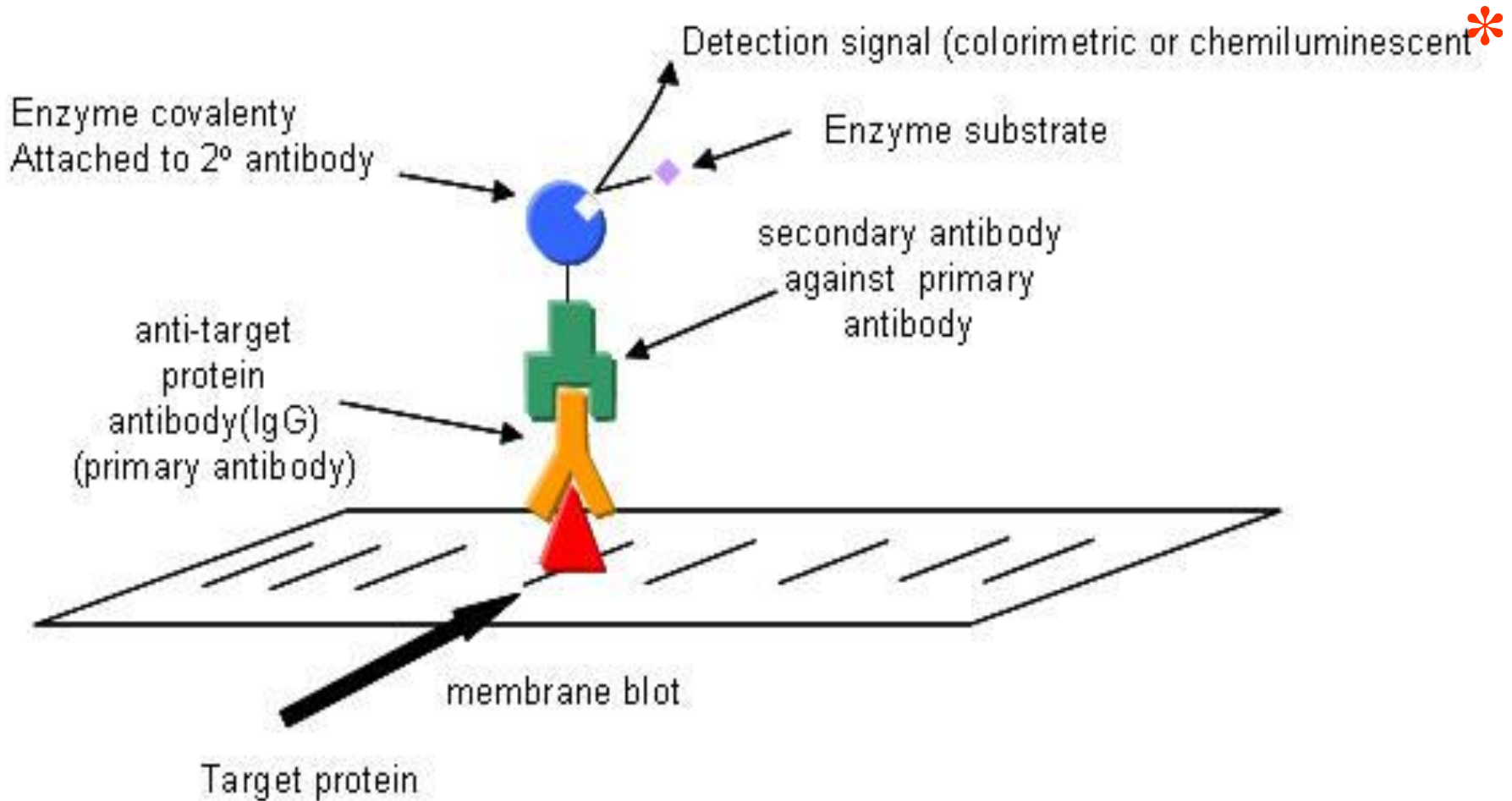

\* Fluorescent westerns use secondary antibodies coupled to fluorophores. Compared to colorimetric detection, the fluorescence signal is more quantitative, easier to generate, more immediate and stable (no enzyme reaction /no substrates). Also, you can utilize different colors to image multiple proteins on the same blot.

# HeLa Cell Lysate

## SDS-PAGE

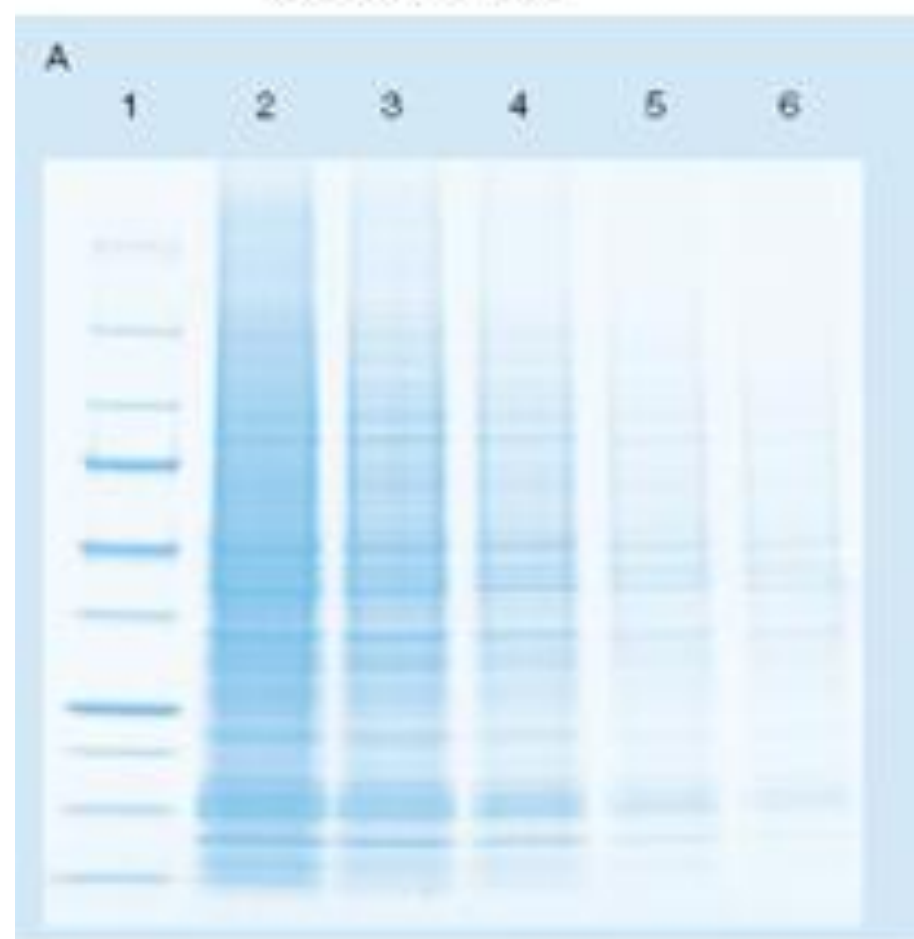

Chemiluminescent Detection of CDK7  
BioRad Bulletin 2032

# HeLa Cell Lysate

## SDS-PAGE

## Western Blot

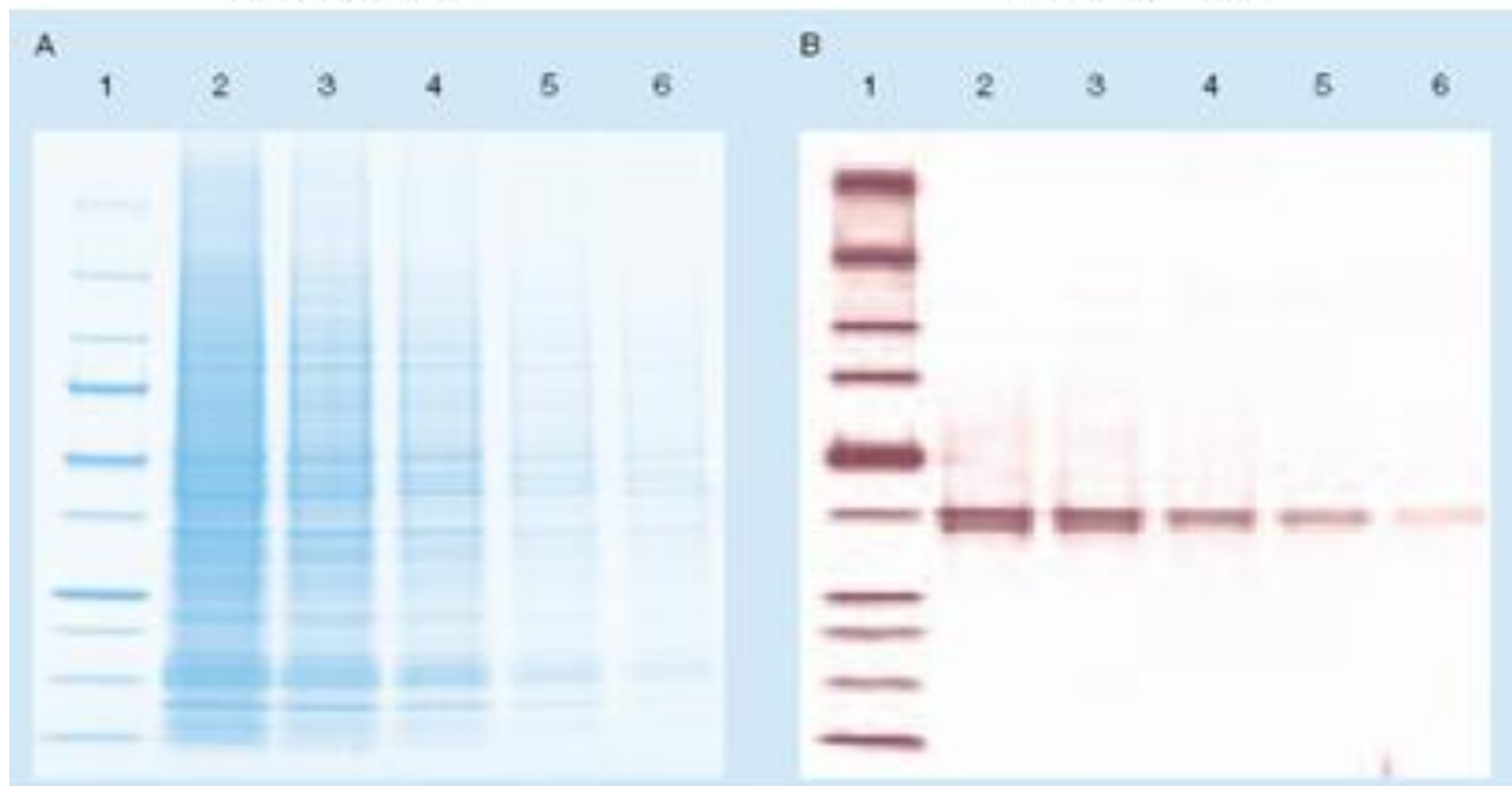

Chemiluminescent Detection of CDK7  
BioRad Bulletin 2032

# Automated DNA sequencing

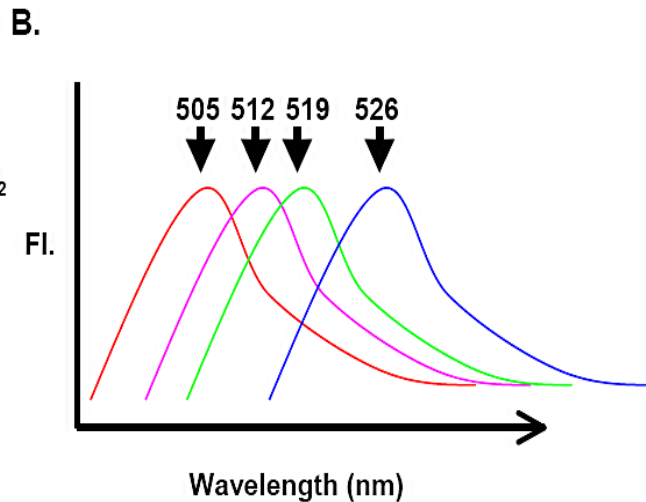
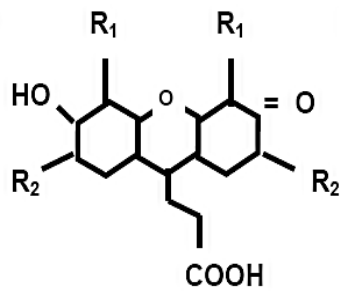
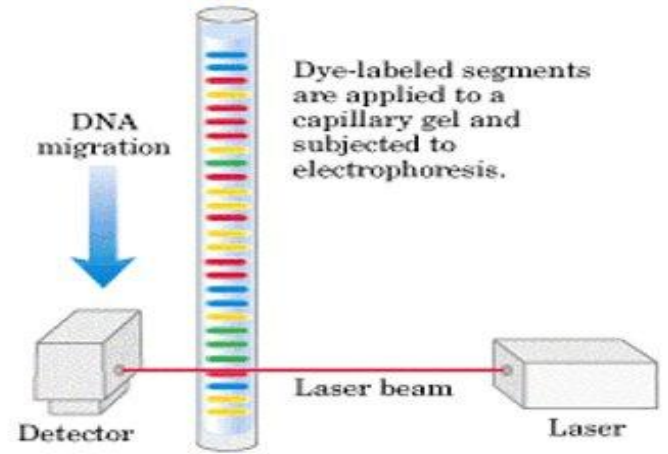
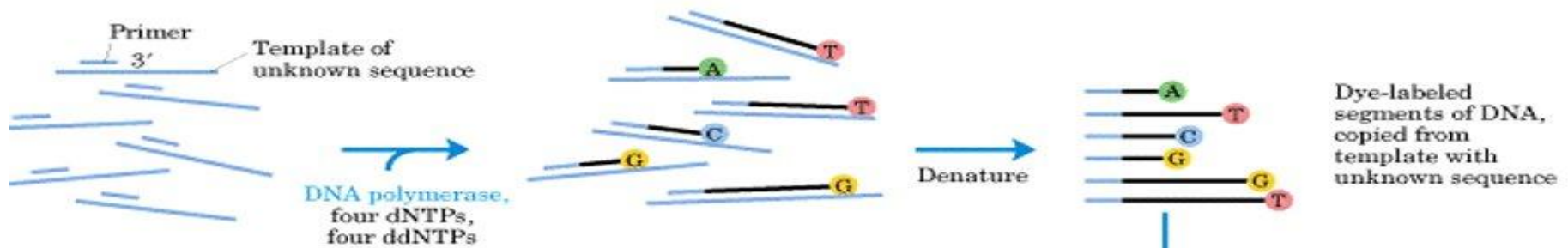

- SF505: R<sub>1</sub>=R<sub>2</sub>=H
- SF512: R<sub>1</sub>=H, R<sub>2</sub>=CH<sub>3</sub>
- SF519: R<sub>1</sub>=CH<sub>3</sub>, R<sub>2</sub>=H
- SF526: R<sub>1</sub>=R<sub>2</sub>=CH<sub>3</sub>

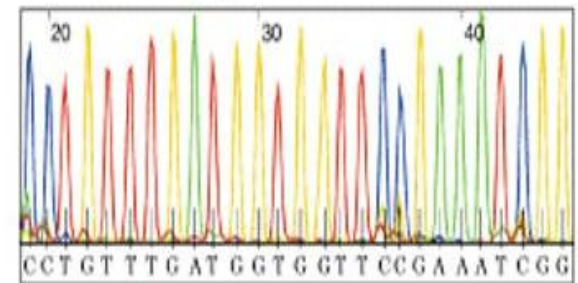

Computer-generated result after bands migrate past detector



# Capillary Electrophoresis (~1960 / 1989)

Limiting factors of traditional electrophoresis:

- 1) detection of molecules after electrophoretic separation
- 2) low voltages needed to prevent heat damage of the samples

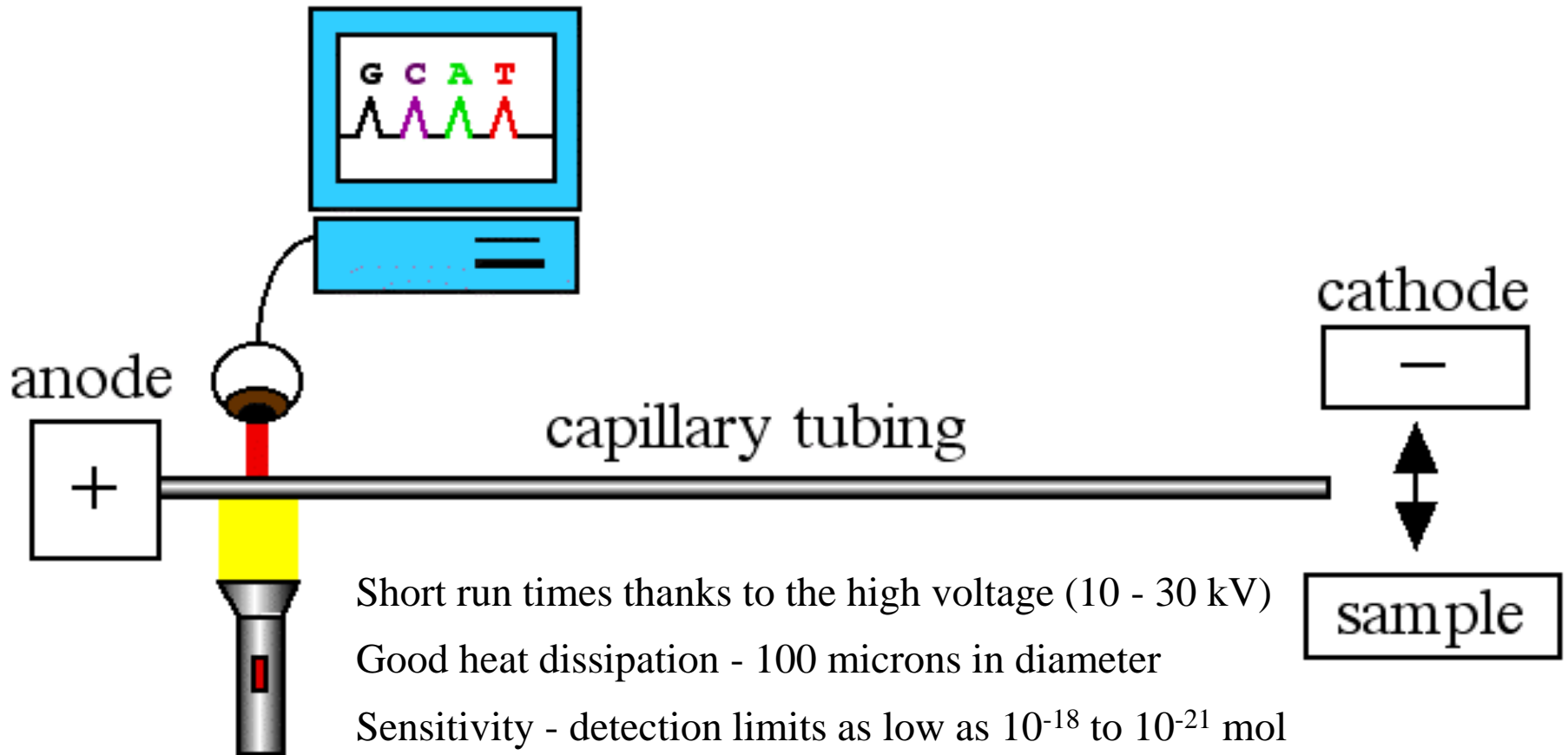

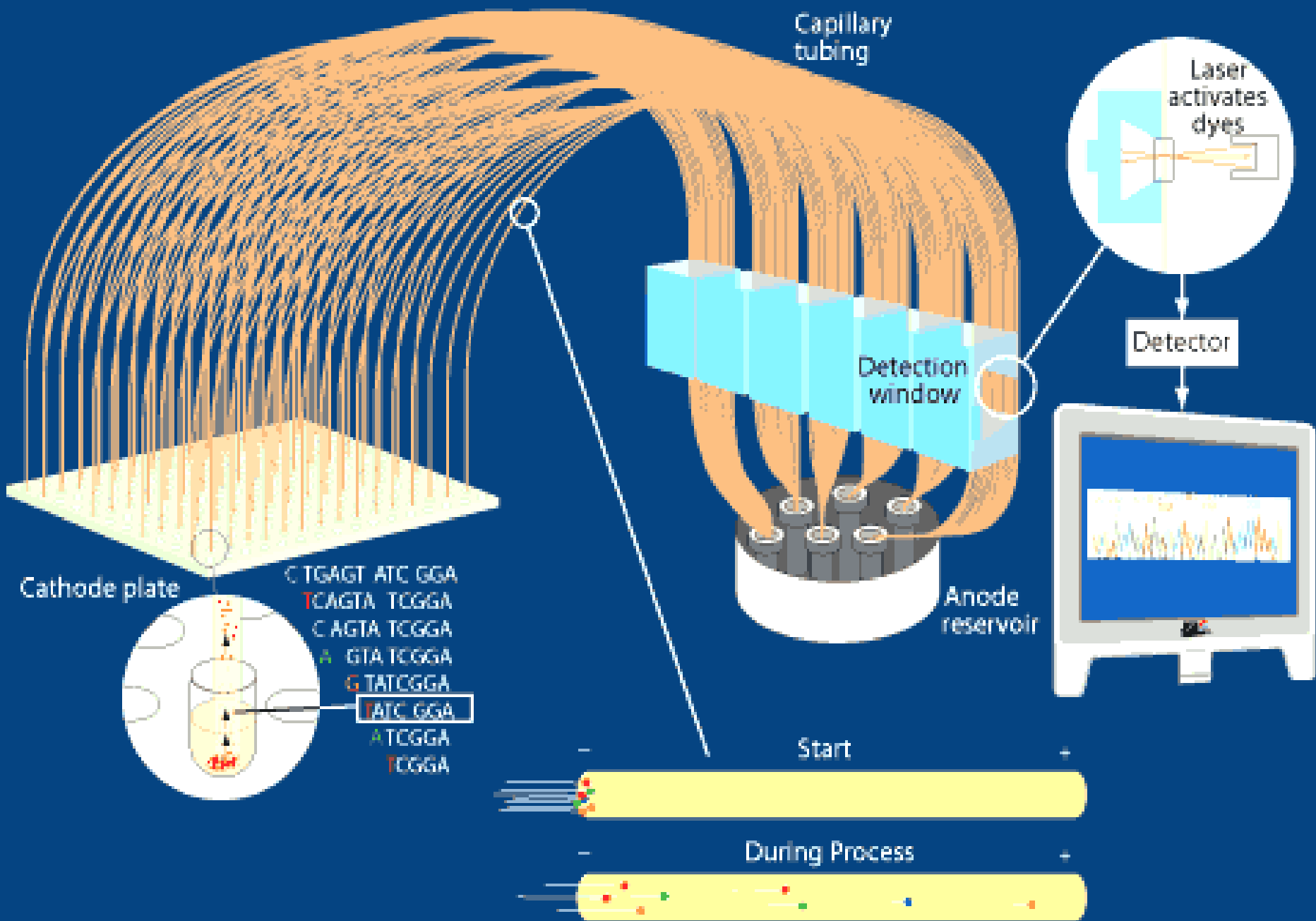

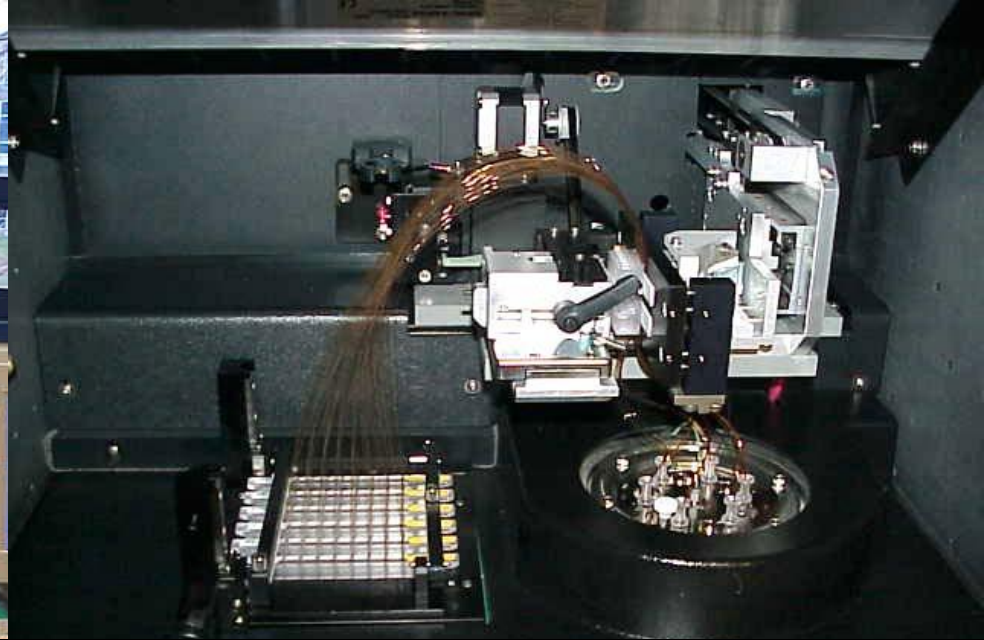

**Megabase Sequencer that analyzes 96 sequencing reactions at a time**

